

CB-GT570 Hardware Specifications

This page provides hardware and electrical documentation for the Controller Board Rev. H2, part number CB-GT570. This is the same LCD controller board integrated with the 5.7" LCD Starter Kit (STK-GT570) and the 5.7" LCD Module Kit (MK-GT570). References to software in this document refer to the Amulet HTMLCompiler. For software documentation please see: <http://www.amulettechnologies.com/help/help.htm>. The controller board is software configurable to drive any size monochrome LCD, up to full VGA (640x480).

The CB-GT570 controller board is ideal for interfacing to a graphics display with CCFL backlighting. Controller Board Overview

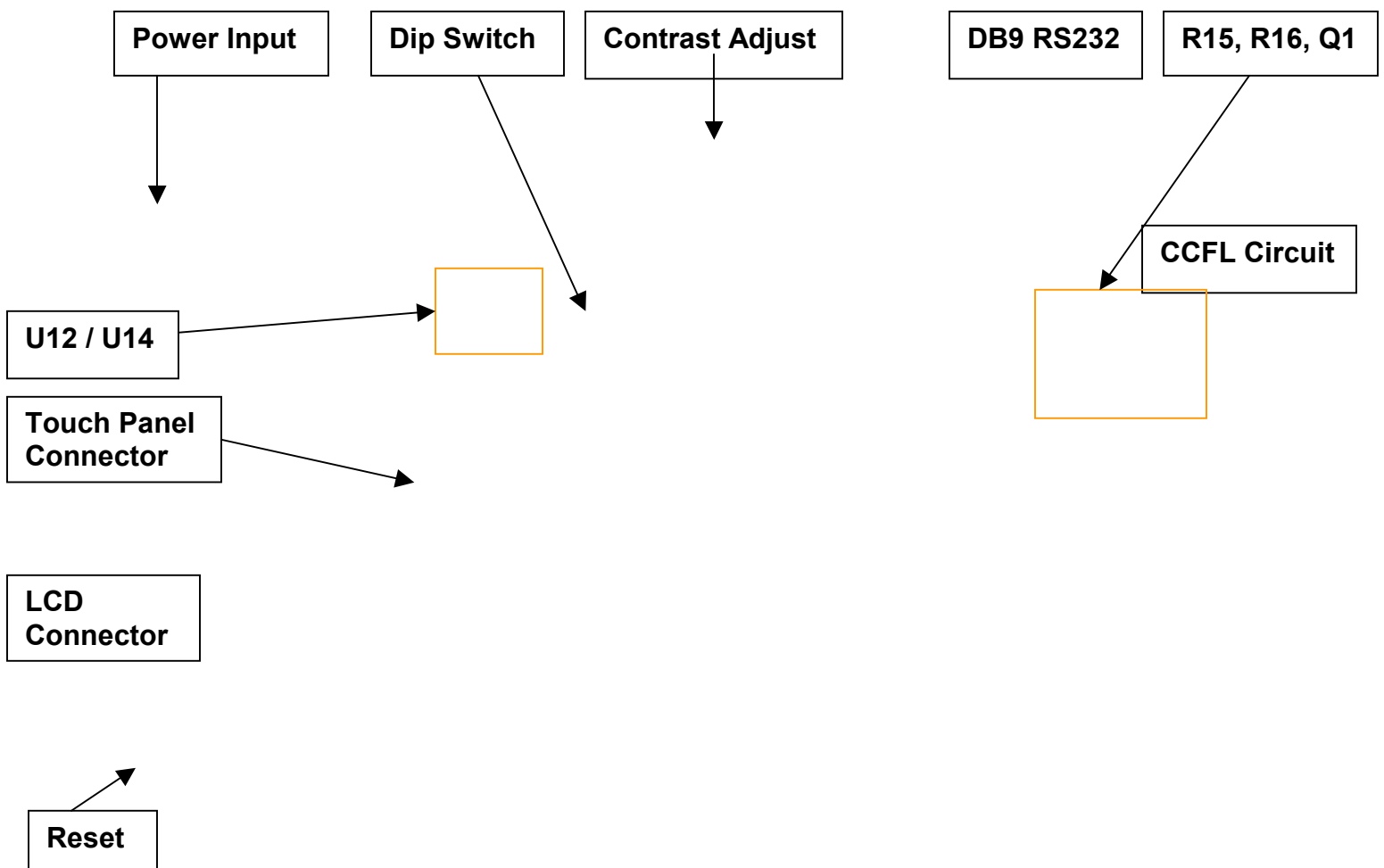

Figure 1. CB-GT570 Controller Board, Component Side.

PCB Size:	6.50" x 4.25"
LCD:	Negative-type display, 4.87" x 3.70" (5.7" diagonal); 320 x 240, monochrome, blue and white ; viewable area 4.76" x 3.61" (121.0 x 91.6mm)
Dot Pitch:	0.36 x 0.36mm
Dot Size:	0.33 x 0.33mm
Touch Panel:	4-wire resistive analog; active area is 118.57 x 89.77mm; utilizes full 320 x 240. NOTE: Since the touch panel is touch activated, do NOT allow your mounting hardware to apply any compression forces inside the active area!
Backlight:	CCFL, always ON. Can be modified to be controlled by digital pot
Operating Temp:	0° to 45°C; 95% RH Max.
Storage Temp:	-25° to 60°C
Power:	12 VDC @ 250mA
SRAM:	128k-Bytes
FLASH:	512k-Bytes (448k-Bytes available)
Serial Port:	RS-232, 9-pin DIN, up to 115.2 Kbps

Table 1. PCB Specs

The controller board is designed to utilize the following crystal frequencies: 10 Mhz, 12 Mhz, 16 Mhz and 20 Mhz. The controller board ships with a 16 Mhz crystal installed, providing an 8 Mhz PIXEL_CLK. Please contact Amulet Technologies via email (support@AmuletTechnologies.com) if you would like to use a 10- 12- or 20 Mhz crystal.

* Characteristics only apply when the controller board is bundled with either the Easy GUI 5.7" LCD Starter Kit or Easy GUI 5.7" LCD Module Kit.

LCD Interface

The timing diagram shown below assumes:

- DATA WIDTH = 8-bits Max. (Adjustable in Software)
- Xsync = Positive Edge Line Pulse (Adjustable in Software)
- CP = Negative Edge Pixel Clock (Adjustable in Software)
- MAXBYTE = 4 bytes of data per line; with the following data in the line buffer: 20, 21, 22, 23

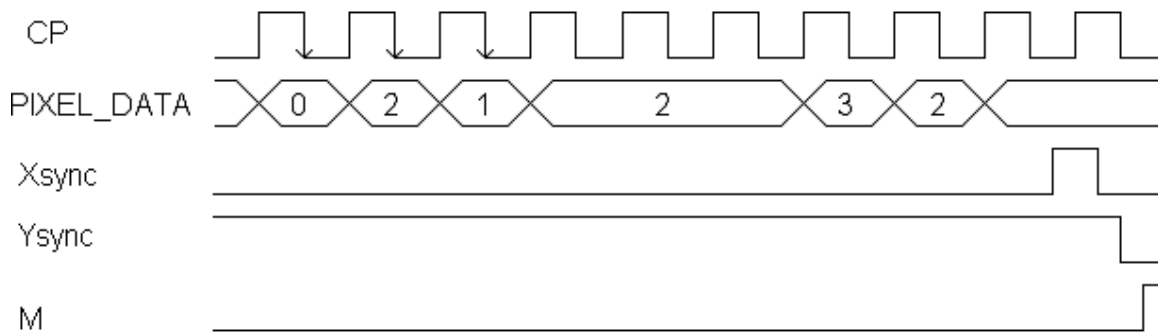

Figure 2. Timing Diagram

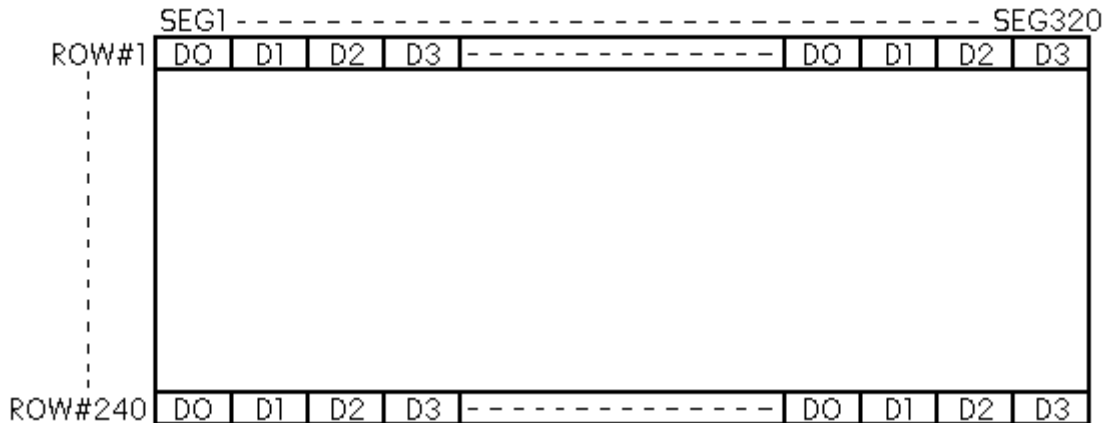

Figure 3. 320x240 Dot Matrix Display Pattern

Headers J1, J2, J7 and J9 provide three alternatives for LCD interface. The Easy GUI Controller Board ships with a 12-pin low insertion force connector installed in header J2. Headers J1 and J2 are pre-routed with a positive drive voltage (variable +17 to +23 VDC). If your display requires a different drive voltage (negative or positive), you must supply this voltage externally. (Contact us: support@AmuletTechnologies.com for more info.) Also, the LCD signals to the interface headers are CMOS level signals. If your LCD requires TTL signals, contact us (support@AmuletTechnologies.com) for simple board modification instructions.

Pin #	Signal	Description
1	D0	Pixel_D3: LCD pixel data
2	D1	Pixel_D2: LCD pixel data
3	D2	Pixel_D1: LCD pixel data
4	D3	Pixel_D0: LCD pixel data
5	DISP OFF	DISP ("H": On; "L": Off): Display control signal
6	FLM	Ysync: Frame signal (LCD first frame synchronization)
7	NC	No Connect

8	LP(CL1)	Xsync : Pixel data latch signal
9	XCK(CL2)	CP : Pixel data shift clock
10	VDD	Power Supply (+5V)
11	VSS	Ground
12	VEE	LCD Driving Voltage (+17 ~ 23V): Positive LCD driving supply
13	VADJ	N/A
14	FGND	Frame Ground

Table 2. LCD Interface Header J1

Pin #	Signal	Description
1	S	Ysync : Frame signal (LCD first frame synchronization)
2	CP1	Xsync : Pixel data latch signal
3	CP2	CP : Pixel data shift clock
4	NC	No Connect
5	DISP OFF	DISP ("H": On; "L": Off): Display control signal
6	D0	Pixel_D3 : LCD pixel data
7	D1	Pixel_D2 : LCD pixel data
8	D2	Pixel_D1 : LCD pixel data
9	D3	Pixel_D0 : LCD pixel data
10	VDD	Power Supply (+5V)
11	VSS	Ground
12	VEE	LCD Drive Voltage (+17 ~ 23V): Positive LCD driving supply

Table 3. LCD Interface Header J2

Pin #	Signal	Description
1	D7	Pixel_D7 : LCD pixel data
2	GND	Ground
3	D6	Pixel_D6 : LCD pixel data
4	D5	Pixel_D5 : LCD pixel data
5	D4	Pixel_D4 : LCD pixel data
6	D3	Pixel_D3 : LCD pixel data
7	D2	Pixel_D2 : LCD pixel data
8	D1	Pixel_D1 : LCD pixel data
9	D0	Pixel_D0 : LCD pixel data

10	LCD PWR	DISP ("H": On; "L": Off): Display control signal
11	LINE_PULSE	Xsync : Pixel data latch signal
12	FRAME_CLK	M : LCD Drive Signal. LCD crystal polarization clock.
13	PIXEL_CLK	CP : Pixel data shift clock
14	FRAME_OUT	Ysync : Frame signal (LCD first frame synchronization)

Table 4. LCD Interface Header J7

Pin #	Signal	Description
1	VH	Power Supply (+12V)
2	VH	Power Supply (+12V)
3	GND	Ground
4	NC	No Connect
5	VL	Power Supply (+5V)
6	GND	Ground
7	VS	Ysync : Frame signal (LCD first frame synchronization)
8	GND	Ground
9	HS	Xsync : Pixel data latch signal
10	GND	Ground
11	VCLK	CP : Pixel data shift clock
12	GND	Ground
13	VD0	Pixel_D3 : LCD pixel data
14	GND	Ground
15	VD1	Pixel_D2 : LCD pixel data
16	GND	Ground
17	VD2	Pixel_D1 : LCD pixel data
18	GND	Ground
19	VD3	Pixel_D0 : LCD pixel data
20	GND	Ground

Table 5. LCD Interface Header J9

Amulet Interface

Header J6 provides a means of interfacing to the Amulet chip.

Pin #	Signal	Description
1	RESET	System Reset (active low)
2	SCLK	SPI Clock
3	MOSI	SPI Data Out (MOSI)
4	MISO	SPI Data In (MISO)
5	SS2	SPI Slave Select (line 2)
6	SS3	SPI Slave Select (line 3)
7	SS4	SPI Slave Select (line 4)
8	SS5	SPI Slave Select (line 5)
9	SS6	SPI Slave Select (line 6)
10	SS7	SPI Slave Select (line 7)
11	IRQ	Interrupt Request
12	GND	Ground
13	GND	Ground
14	GND	Ground
15	BOOT	System Power Up Mode (1 = Program, 0 = Normal)
16	GND	Ground
17	BAUD	Flash Baud Rate (1 = 115200, 0 = 19200)
18	GND	Ground
19	RAM	RAM Test (1 = Normal, 0 =Test)
20	GND	Ground
21	T_CAL	Touch Panel Calibration (0 = Normal, 1 = Calibrate)
22	GND	Ground
23	GND	Ground
24	GND	Ground
25	TXD	UART Transmit Data U1 Side
26	RXD	UART Receive Data U1 Side
27	TXD	UART Transmit Data U7 Side
28	RXD	UART Receive Data U7 Side
29	GND	Ground
30	GND	Ground
31	TXD IN	Transmit Data J8 Pin2 DB9
32	RXD IN	Receive Data J8 Pin3 DB9

Table 6. Amulet Interface Header J6

CCFL Interface

WARNING: Electrical shock hazard! Do not touch the CCFL inverter with power applied to the board. Doing so can shock and burn you.

The Easy GUI controller board comes equipped with an inverter for driving a CCFL backlight via 2-pin header J10.

 <p>WARNING HIGH VOLTAGE!</p>	Pin #	Signal	Description
	1	OUT1	Power supply for CCFL backlight (HOT)
	2	OUT2	Power supply for CCFL backlight (GND)

Table 7. CCFL Interface Connector J10

Backlight Controlled by Digital Pot

Part Reference	Package	Description	Manufacturer	Manufacturer Part #
R15	0805	Res, 10K, 1/10W, 5%	Panasonic	ERJ-6GEY103V
R16	0805	Res, 1K, 1/10W, 5%	Panasonic	ERJ-6GEYJ102V
U14	μ SOIC	Digital Pot, 10K	Analog Devices	AD5200BRM10
Q1	TO-92	Small Signal Trans.	Fairchild	MPSA12

Table 8. Adding components to control the backlight.

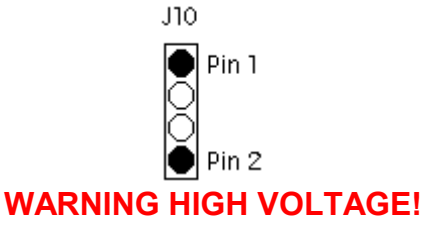
Remove the jumper across Q1 and install the components.

See the SPI-Based Contrast and Backlight Control help documentation for any firmware questions.

Touch Panel Interface

The Easy GUI controller board includes a built-in touch panel decoder chip (U2). Headers J4 and J5 provide two touch panel interface options. The board ships with a 4-pin ZIF (zero insertion force) connector installed in J4.

Pin #	Signal	Description
1	X-	X- Position Input
2	Y+	Y+ Position Input
3	X+	X+ Position Input
4	Y-	Y- Position Input

Table 9. Touch panel Interface Connector

Touch panel calibration data is stored in FLASH ROM as part of the Amulet Operating System (OS). Therefore, always recalibrate the touch panel after restoring or updating the OS. To perform a touch panel calibration, proceed as follows:

1. Make sure that the DIP switch settings on SW2 are as follows:

Switch 1 ON -- Boot Mode
Switch 2 OFF -- Flash Mode Baud Rate
Switch 3 OFF -- RAM Test
Switch 4 OFF – Touch panel Mode
2. Press the Reset Switch to reboot the board. The board reboots in the calibration mode.
3. A series of three targets appear on the LCD. The first two targets are X and Y calibration targets. Using a touch panel stylus, touch the center of each target as it appears. As a target is touched, the next target is displayed.
4. The third target is a calibration "check" target. Unlike the first two targets, this target appears momentarily pressed while touched. Depending on how you remove the stylus from this target, the calibration will either restart, or the calibration will end. To check calibration accuracy, move the stylus within the center of the target with a continuous touch, and then move the stylus off the edge of the target image. A well-calibrated target will remain pressed with the stylus in the center area, and should return to its pre-pressed state as the stylus moves off the edge of the target.

5. If the calibration is satisfactory, release the stylus anywhere within the target. (The unit will proceed to the μ HTML Home Page.) If the calibration is NOT satisfactory, release the stylus anywhere outside the target to restart the calibration.
6. If the calibration is satisfactory, then make sure you return the Touch panel Mode DIP switch (Switch 4) to the Normal Mode (ON) before you press the reset switch or re-apply power to the board. If not, the board will restart in the touch panel calibration mode.

Touch panel calibration can also be entered via software, by using the Amulet:calibrate() function call.

NOTES:

- A copy of the touch panel calibration pages are stored in ..\Amulet\Projects\OS Files\touch\. The three pages (Target1.html, Target2.html and Target3.html) are setup specifically for 1/4 VGA (320 X 240) displays.
- If a display with a different resolution is used, the size of the tables in Target1.html, Target2.html and Target3.html should be changed to match the resolution of the display. Once the dimensions of the table have been changed to match the correct resolution, open Touch.ahtml in the HTMLCompiler and then program into the flash. Touch.ahtml sends out the initialization values for the SPI-based contrast and backlight adjust and then jumps to Target1.html.
- The target image (target2.gif) can be replaced with a custom image if you like. The same target must be used in all three calibration pages, though.

Power Supply and Reset

The controller board comes equipped with a 2.5 mm external power connector (J3). The power requirement is 12 VDC @ 250 mA. A reset switch (momentary pushbutton, SW1 on the back of the board) resets the Amulet graphical OS chip as well as LCD power.

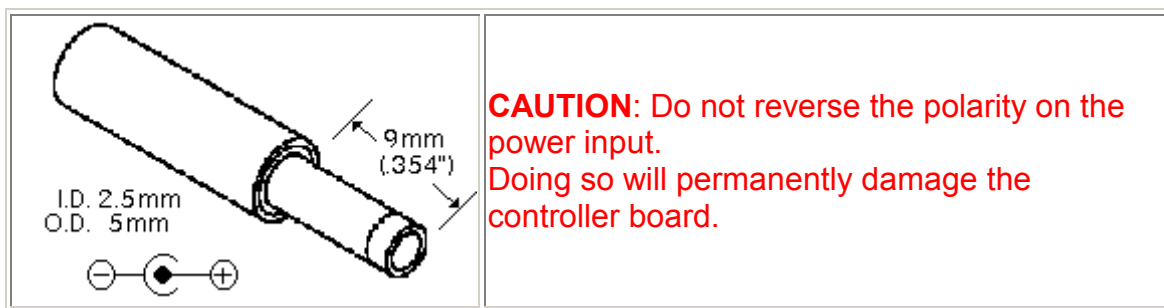

Figure 4. Power Supply Input

DIP Switch Settings

The Easy GUI controller board can be powered up in different modes via the settings of the DIP switch (SW2). Some of the power-up modes include: programming mode, run mode, RAM test mode, and touch panel mode.

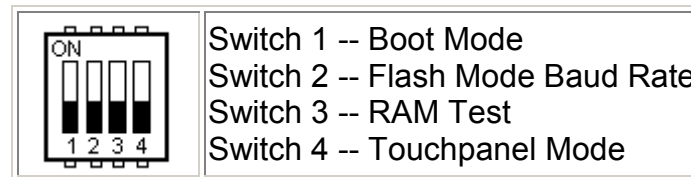

Figure 5. DIP Switch Settings

Boot Mode (Switch 1) -- This switch is monitored during a reboot to determine the operational mode of the controller board; ON is the normal mode and OFF is the FLASH program mode. The only time you should have to set Switch 1 to OFF (program mode) is when the project you compiled locks up the Amulet OS to the point where it won't accept the wake up message or if the Amulet OS has been corrupted and you need to [reload the OS](#).

Flash Mode Baud Rate (Switch 2) -- This switch sets the baud rate used during a Flash Reprogram. The ON position sets the hardware to 19,200 baud; OFF sets the hardware to 115,200 baud. This setting must match the baud rate selected in the Amulet Compiler software.

RAM Test (Switch 3) -- Turn this switch ON and then reboot the controller board to auto-execute a RAM test. A RAM test failure will result in a zero (0) volt signal on the MEM PASS test pad on the board; a pass will result in a 3.3 volt signal. The switch must be returned to the normal mode (OFF) before the next reboot to continue normal operation.

Touch panel Mode (Switch 4) -- This switch should remain ON during normal operation. Turn this switch OFF and then reboot the controller board to begin a touch panel calibration. The controller will display a series of three calibration targets. Use a stylus to touch the center of each target. If necessary, the controller will repeat the calibration. When calibration is complete, the controller will return to normal operation. The switch must be returned to the normal mode (ON) before the next reboot to continue normal operation.

NOTES:

- A copy of the "Please wait while programming flash..." page is stored in ..\Amulet\Projects\OS Files\Flashing\Flashing.ahtml. It is setup specifically

for 320 X 240 displays. If a different sized display is used, the size of the table in Flashing.ahtml should be changed to match the dimensions of the new display. Once the dimensions have been changed, open Flashing.ahtml in the HTMLCompiler and then program into the flash.

- The text in Flashing.ahtml can be changed, but no images can be added.

Contrast Adjust Setting

By default, the Easy GUI controller board ships with a positive DC/DC converter with a variable output of +17 to +23VDC (variable by rotating the contrast adjust potentiometer VR1). Not all LCD's require a positive LCD driving voltage (see LCD Interface section above for more information). To have the Easy GUI controller board generate a negative LCD driving voltage having a variable output of -15.5 to -23VDC (variable by rotating the contrast adjust potentiometer VR1), proceed as follows:

1. Cut the trace shorting C29 and add a .22uF capacitor.
2. Remove D1 and turn it around, so the cathode end faces D1 text.
3. Add D2 which is the same as D1, so the anode end faces D2 text.
4. Replace U8 with LT1617ES5.
5. Replace R3 with 560K ohm resistor.
6. Replace R4 with 33K ohm resistor.
7. Short VR2 pin 2 (center pin) to VR2 pin 3 (pin closest to SW3).
8. Flip capacitor at location C6 around.
9. Add a .22uF capacitor to C28.

Part Reference	Package	Description	Manufacturer	Manufacturer Part #
C28,C29	1206	CAP, .22uF, 16V, Z5U, 20%	Panasonic	ECP-U1C224MA5
D2	SOD-123	Diode, Schottky, .5A, 20V	On Semi	MBR0520
U8	SOT-23	Negative DC/DC Converter	Linear Technology	LT1617ES5
R3	0805	RES, 560K, 1/10W, 5%	Panasonic	ERJ-6GEYJ564V
R4	0805	RES, 33K, 1/10W, 5%	Panasonic	ERJ-6GEYJ333V

Table 10. Negative Driving Voltage Parts

NOTE:

- The negative variable output range can be decreased or increased by using different R3 and R4 resistor values. Consult the datasheet for the LT1617 negative DC/DC converter to calculate values for R3 and R4 for a specific output range.

Digital Controlled Contrast

Part Reference	Package	Description	Manufacturer	Manufacturer Part #
U12	μSOIC	Digital Pot, 10K	Analog Devices	AD5200BRM10
R4	0805	51K Resistor 1/10W 1%		

Install U12 and Remove VR1.

See the SPI-Based Contrast and Backlight Control help documentation for any firmware questions.

RS-232 Spec

A serial connection is required between the controller board and a personal computer in order to program μHTML pages into the FLASH memory of the controller board.

- Pin 1 - N/C
- Pin 2 - TX (Amulet GUI module transmits data on Pin 2 while the PC receives data on Pin 2)
- Pin 3 - RX (Amulet GUI module receives data on Pin 3 while the PC transmits data on Pin 3)
- Pin 4 to 6 - Jumpered
- Pin 5 - Ground
- Pin 7 to 8 - Jumpered
- Pin 9 - N/C

The serial parameters for communications between the Easy GUI client and the server are, as follows:

Baud Rate: 9600, 19200, 57600, or 115200bps
Parity: None
Data Bits: 8
Stop Bits: 1

See Communications [Protocol](#) for more information.

Module Assembly 5.7" Starter and Module Kits

The .pdf version of the Mechanical Drawing for the 5.7" Module Kit can be found at <http://www.amulettechnologies.com/help/Images/Sharp.pdf>

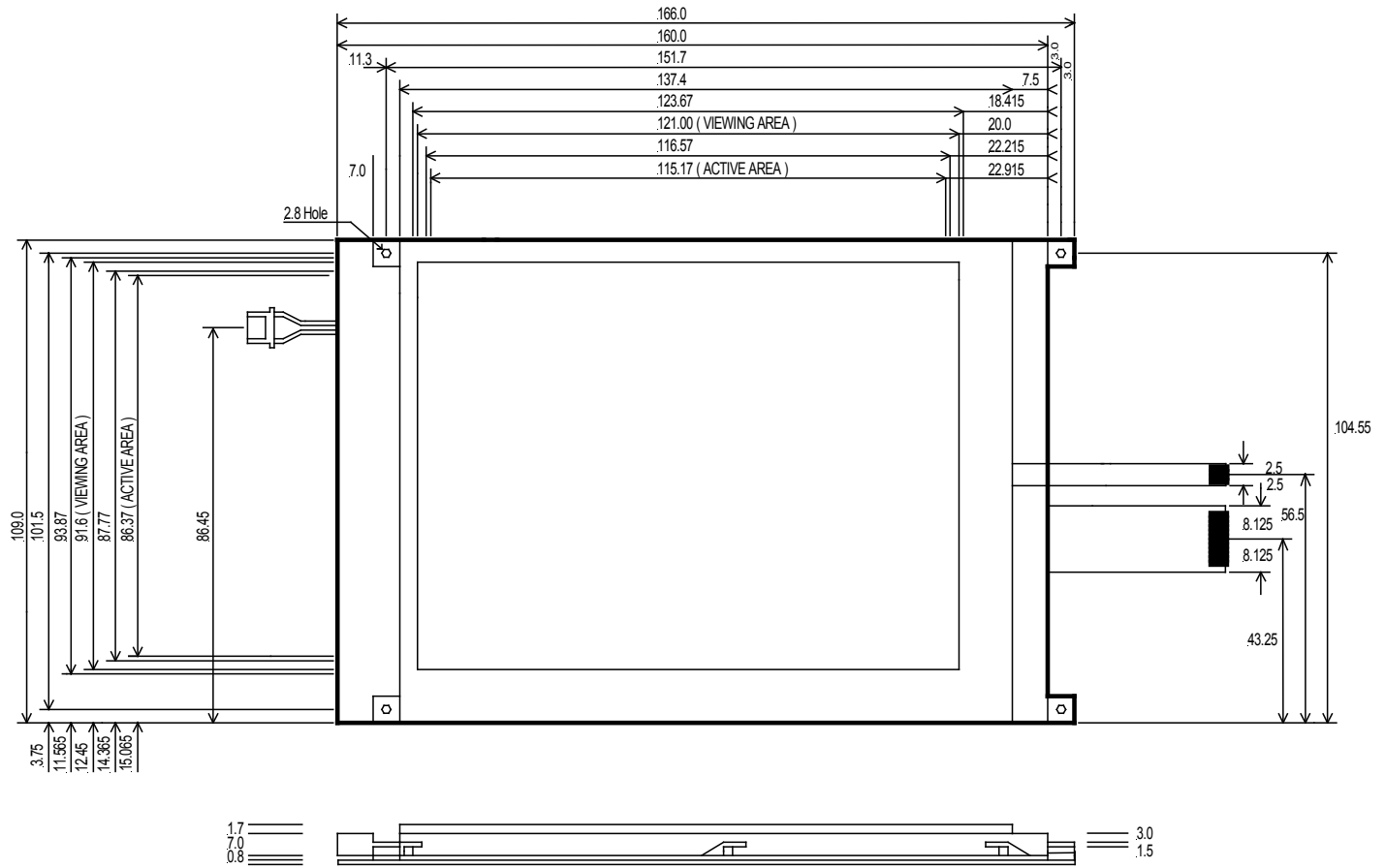

Bezel Mechanical Drawing

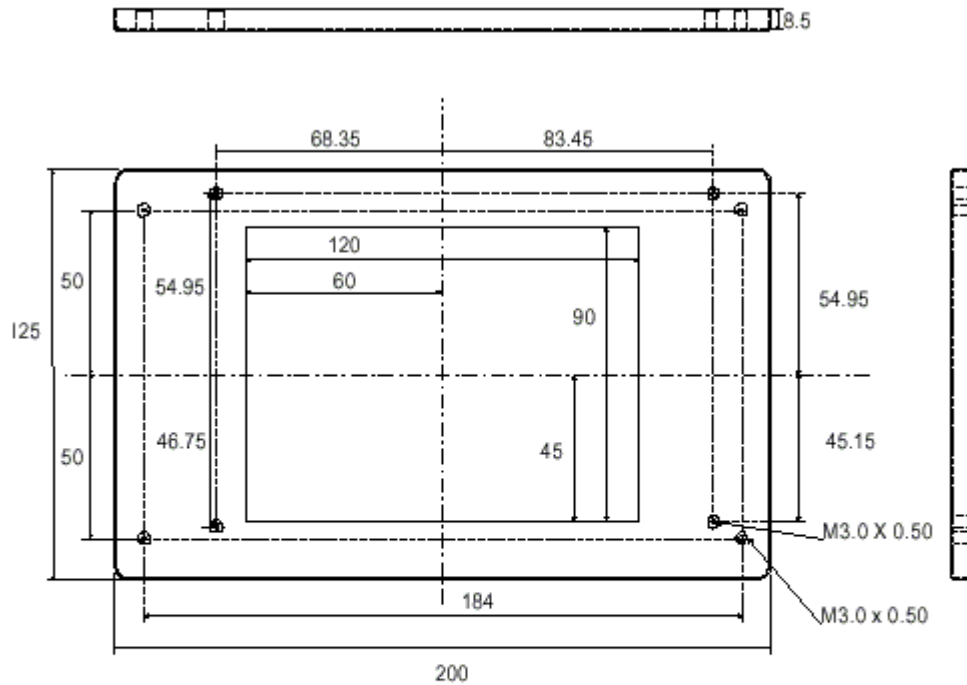

Material : Steel
Finish : Grey Powder Coat
Dimensions in mm

*Amulet HTMLCompiler,
Copyright © 2002-2004 by
Amulet Technologies, LLC*

Rev A.... 6/18/04
Rev B.... 8/18/04
Rev C...12/03/04